



Technical Information

DX1-LYNX

XMC-Module

Micro SATA SSD
Solid State Drive Mezzanine Module

Document No. 5527 • Ed. 9 • 10 April 2012



Contents

About this Manual	3
Edition History	3
Related Documents	4
Nomenclature	4
Trade Marks	4
Legal Disclaimer - Liability Exclusion	4
Standards	5
Summary of Features	6
Short Description	7
Block Diagram	11
Top View	12
Back Side View	13
Front Bezel	14
Typical Assembly on Host Carrier	16
Installing and Replacing Components	17
Before You Begin	17
Warnings	17
Caution	17
Installing the Board Assembly	18
Removing the Board Assembly	19
EMC Recommendations	20
Technical Reference - Connectors and Jumpers	21
Caution	21
Please Note	21
J1 BIOS Selection	22
P1 P2 Micro SATA Receptacles	23
P3 P4 eSATA Connectors	25
P14 Mezzanine Connector	26
P15 Mezzanine Connector	28
Schematics	31

About this Manual

This manual is a short form description of the technical aspects of the DX1-LYNX, required for installation and system integration. It is intended for the advanced user only.

Edition History

EKF Document	Ed.	Contents/Changes	Author	Date
Text # 5527 dx1_tie.wpd	1	Technical Information DX1-LYNX English, Preliminary Edition	jj	03 April 2009
	2	Added information regarding BIOS Flash	jj	23 April 2009
	3	Added illustrations regarding SSD mounting frame(s)	jj	18 May 2009
	4	Modified illustrations (position of SSD adjusted)	jj	5 June 2009
	5	Added photos top/bottom view	jj	28 October 2009
	6	Added photos panorama view, front view, profile view	jj	10 November 2009
	7	Added photo explosion view of CCG CCK DX1 C20	jj	24 November 2009
	8	Added photos SK2-SESSION XMC module carrier w. DX1-LYNX	jj	3 April 2012
	9	Added photo SK2-SESSION & DX1-LYNX exploded view	jj	10 April 2012

Related Documents

Related Information	
DX1-LYNX XMC Module SATA I/O	www.ekf.com/d/dide/dx1/dx1_e.html
DE4-FOX PMC Module SATA I/O	www.ekf.com/d/dide/de4/de4_e.html
CCK-MARIMBA XMC Carrier Side Board	www.ekf.com/c/ccpu/cck/cck_tie.pdf
SK2-SESSION CompactPCI® Serial XMC Carrier Card	www.ekf.com/s/sk2/sk2.html

The DX1-LYNX is a XMC style mezzanine card (i.e. PCI Express® based). A similar PMC solution (PCI based) is available as an alternate, named DE4-FOX.

Nomenclature

Signal names used herein with an attached '#' designate active low lines.

Trade Marks

Some terms used herein are property of their respective owners, e.g.

- ▶ CompactPCI, CompactPCI PlusIO, CompactPCI Serial: ® PICMG
- ▶ Windows: ® Microsoft
- ▶ EKF, ekf system: ® EKF

EKF does not claim this list to be complete.

Legal Disclaimer - Liability Exclusion

This document has been edited as carefully as possible. We apologize for any potential mistake. Information provided herein is designated exclusively to the proficient user (system integrator, engineer). EKF can accept no responsibility for any damage caused by the use of this manual.

Standards

Reference Documents		
Term	Document	Origin
CompactPCI®	CompactPCI Specification, PICMG® 2.0 R3.0, Oct. 1, 1999	www.picmg.org
CompactPCI® PlusIO	CompactPCI PlusIO Specification, PICMG® 2.30 R1.0, November 11, 2009	www.picmg.org
CompactPCI® Serial	CompactPCI Serial Specification, PICMG® CPCI-S.0 R1.0, March 2, 2011	www.picmg.org
Micro SATA	SFF-8144 Specification	ftp://ftp.seagate.com/sff
PCI Express®	PCI Express® Base Specification 3.0	www.pcisig.com
PCI Local Bus	PCI 2.2/2.3/3.0 Standards PCI SIG	www.pcisig.com
SATA	Serial ATA 2.5/2.6 Specification	www.sata-io.org
XMC	ANSI/VITA 42.0 & 42.3, IEEE P1386.1 / Draft 2.4 & Draft 2.4a	www.vita.com

Summary of Features

Feature Summary	
Form Factor	<ul style="list-style-type: none"> ▶ XMC single-width mezzanine card 149mm x 74mm ▶ Stack height 10mm XMC to host
Host I/F Connectors	<ul style="list-style-type: none"> ▶ P15 XMC - PCI Express, single lane, single link ▶ P14 PMC (Option) - Rear I/O SATA
SATA Controller	<ul style="list-style-type: none"> ▶ JMB363 PCI Express to SATA controller ▶ Dual-channel SATA II 3Gbps ▶ Option RAID Level 0/1/10 ▶ Serial ATA AHCI compliant ▶ Supports SATA II Gen1m and Gen2m (eSATA) ▶ Supports Native Command Queuing (NCQ) ▶ Drivers available at ftp://driver.jmicron.com.tw/jmb36x/
Solid State Drive	<ul style="list-style-type: none"> ▶ Module suitable for 1.8-inch Micro SATA SSD (alternatively hard disk drive), dimensions according to SFF-8144 (54mm x 78.5mm x 5mm) ▶ Variety of industrial grade Micro SATA SSD manufacturers, e.g. Intel, Micron, Samsung, SanDisk, STEC, Supertalent, 64GB or beyond, SLC or MLC available, high speed data transfer ▶ SSD can be provided by EKF or by customer ▶ Single- or dual-drive option (RAID option for dual-drive)
SATA Connectors	<ul style="list-style-type: none"> ▶ Each SATA channel can be individually assigned either to an on-board drive, to a front bezel eSATA receptacle, or to the rear I/O connector (these are permanent manufacturing options, consider before ordering) ▶ P1: 15-pos. Micro SATA connector, suitable for 1.8-inch top mount drive (side 1 - module component side), option ▶ P2: 15-pos. Micro SATA connector, suitable for 1.8-inch bottom mount drive (side 2 - module back side), option ▶ P3, P4: Front bezel eSATA receptacles channel 1 / 2, option ▶ P14: PMC rear I/O connector, option
Thermal Conditions	<ul style="list-style-type: none"> ▶ Operating temperature: 0°C ... +70°C ▶ Storage temperature: -40°C ... +85°C, max. gradient 5°C/min ▶ Humidity 5% ... 95% RH non condensing
Environmental Conditions	<ul style="list-style-type: none"> ▶ Altitude -300m ... +3000m ▶ Shock 15g 0.33ms, 6g 6ms ▶ Vibration 1g 5-2000Hz
EC Regulations	<ul style="list-style-type: none"> ▶ EN55022, EN55024, EN60950-1 (UL60950-1/IEC60950-1) ▶ 2002/95/EC (RoHS)
MTBF	tbd

Not all of the connectors may be present or functional on your actual DX1-LYNX board; assembly is highly custom specific. Options may be exclusive, i.e. not necessarily concurrently present. Discuss your needs with EKF before ordering.

Short Description

The DX1-LYNX is a XMC style single-width mezzanine card, equipped with a dual-channel PCI Express to SATA II controller, and one or two 1.8-inch Micro SATA solid state drives (SSD). The SATA controller allows RAID or non RAID operation. As an alternate (assembly options) to the on-board drive(s), each SATA channel can be used for attachment of external SATA storage devices, either through the front bezel connectors (eSATA type), or via rear I/O (across the P14 connector to a suitable host carrier board).

As of current, suitable on-board mounting Micro SATA solid state drives are available with 64GB and beyond storage capacity, delivering sufficient space for installation of any popular operating system.

A single drive will be mounted on the component side (side 1) of the mezzanine card (facing the carrier board when module is engaged). As an option, a second drive can be accommodated on the back side (module side 2, on top of the stack when mezzanine card is engaged).

Flash technology based SATA drives, both SLC and also MLC architecture, provide significant advantages compared to rotating memory solutions (aka hard disk), e.g. less power consumption, faster data I/O transfers, lower latency time, industrial temperature grade and superior immunity against shock and vibration. Nevertheless also a hard drive with Micro SATA connector could be employed on the DX1-LYNX, for potential cost savings.





Assembly Unit DX1-LYNX XMC Module & SK2-SESSION Carrier Card

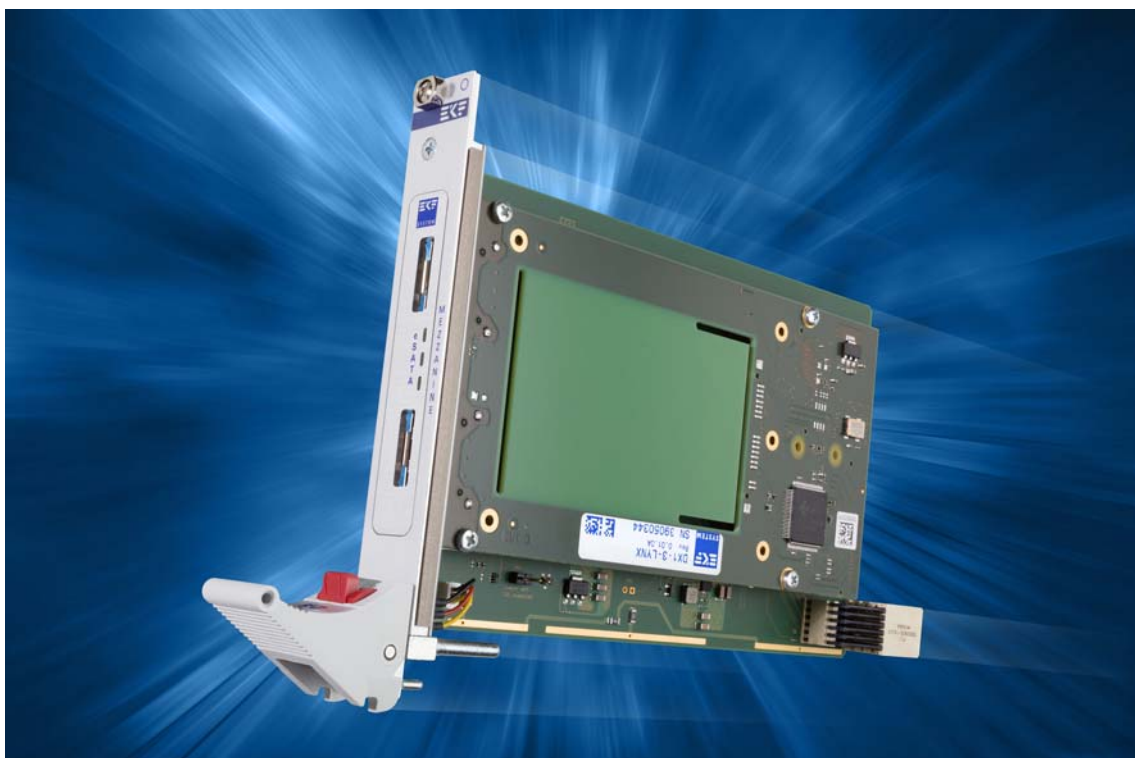



Intel MicroSATA SSD (Top View)



Samsung MicroSATA SSD
(Bottom View)



Sandisk MicroSATA SSD



Supertalent MicroSATA SSD
(Bottom View)



CPU Board • PMC/XMC Carrier Side Card • DX1-LYNX XMC Module (Dual Drive)

Block Diagram

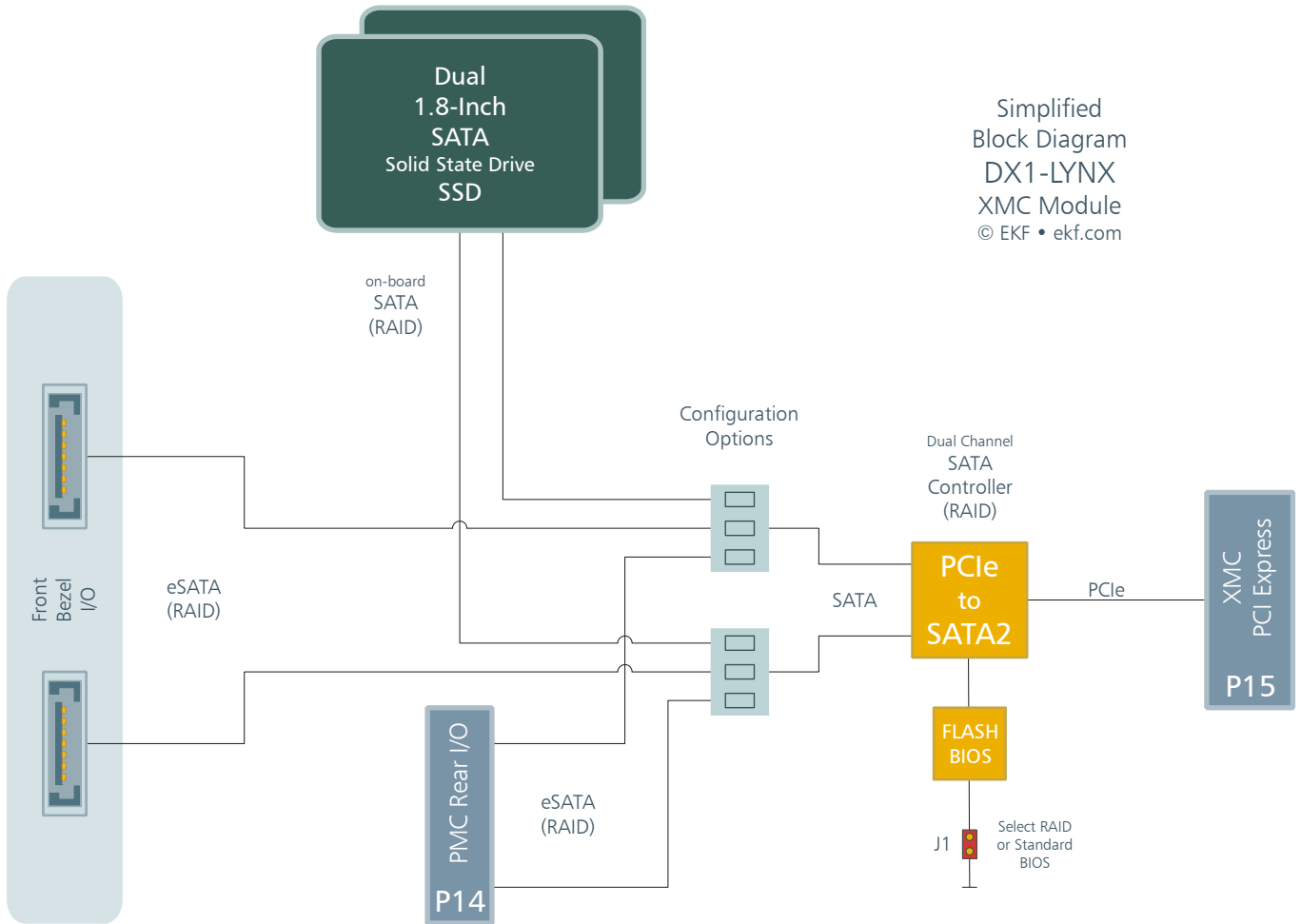

Simplified Block Diagram
DX1-LYNX
XMC Module
© EKF • ekf.com

Top View

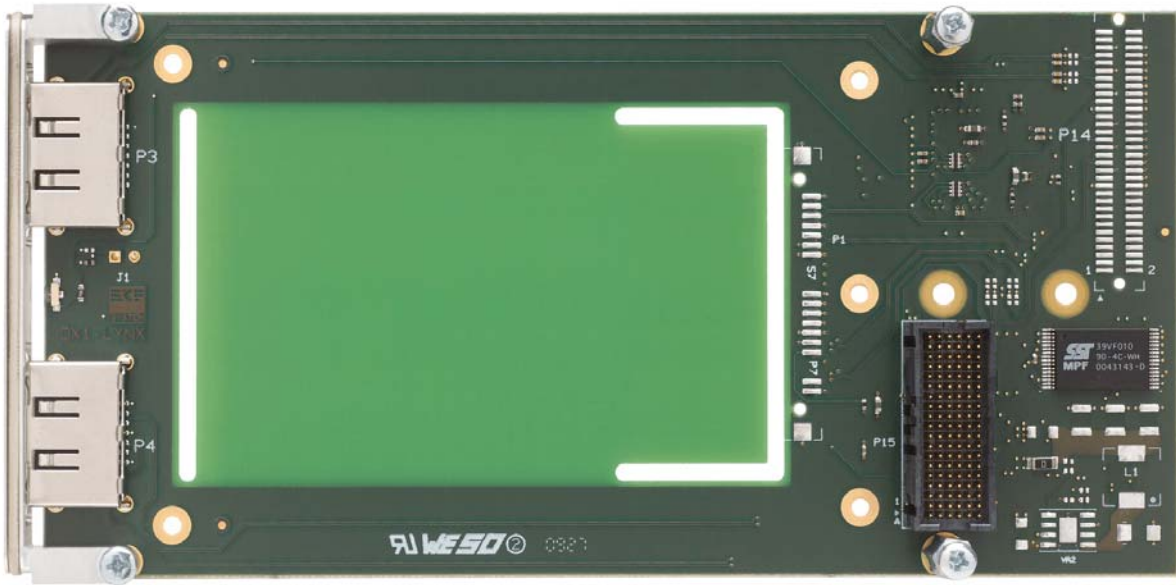

Back Side View

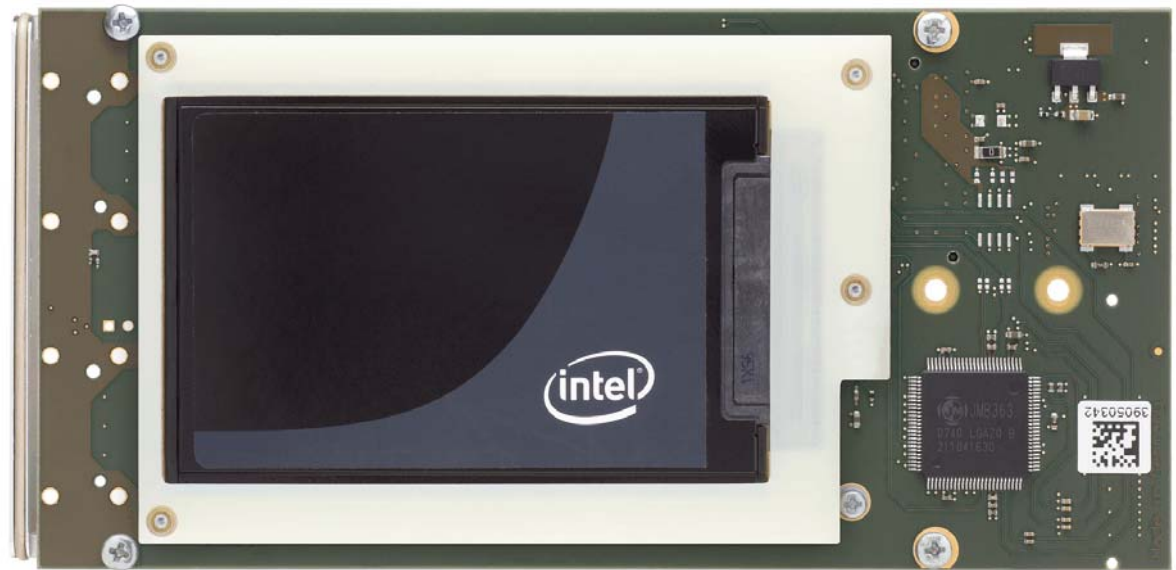
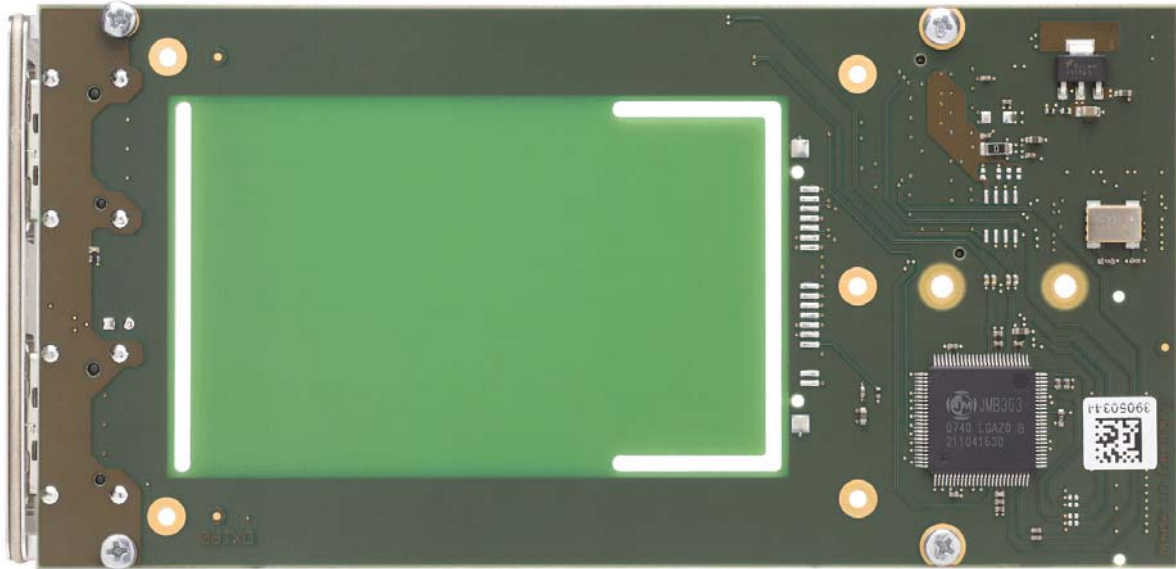

Front Bezel

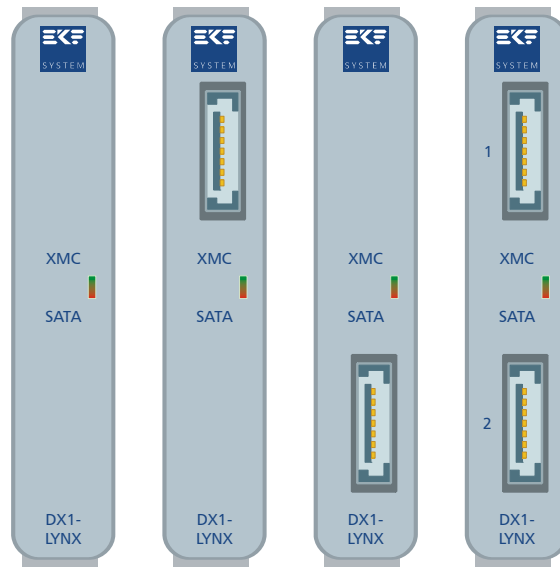



Typical Assembly on Host Carrier

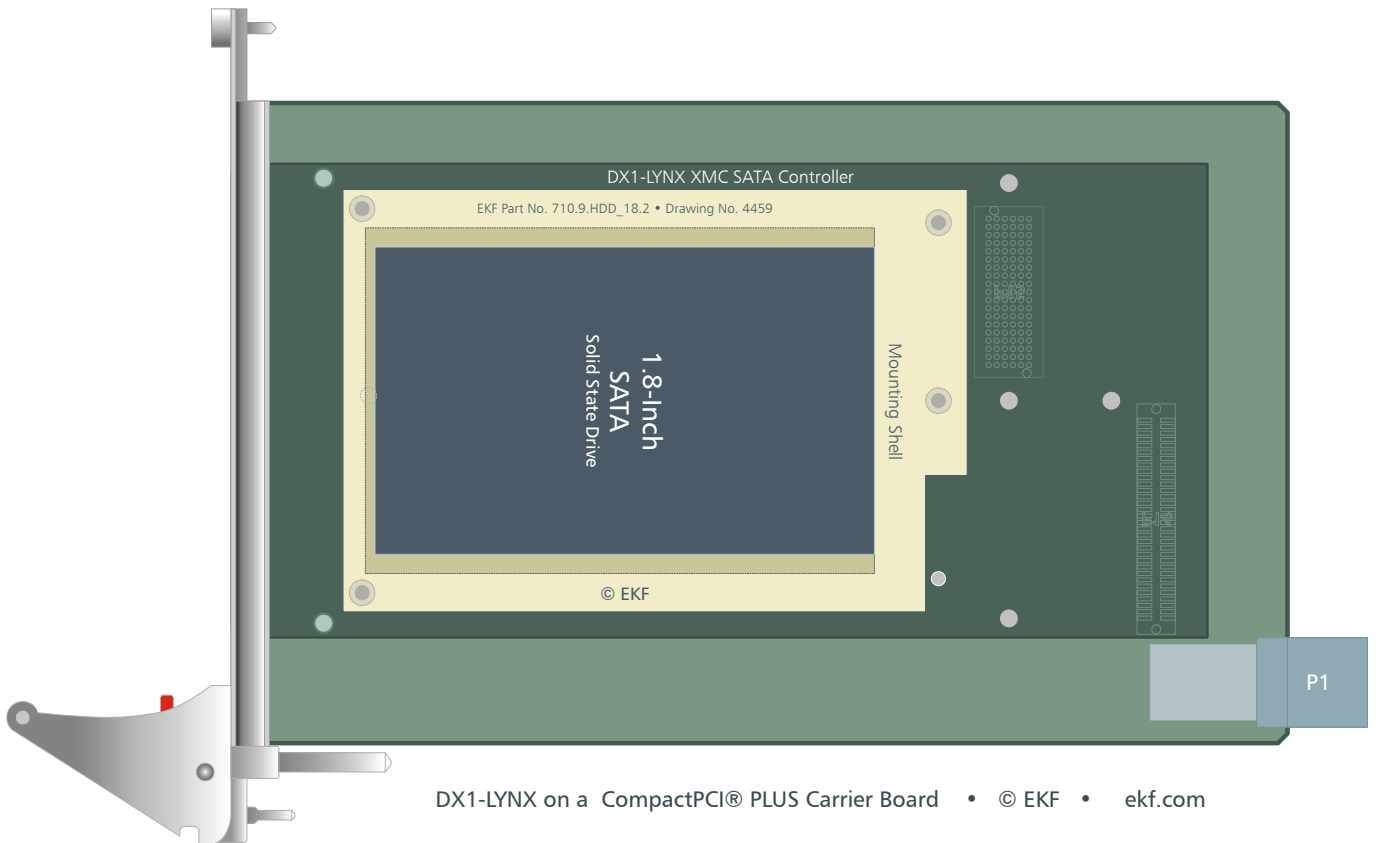
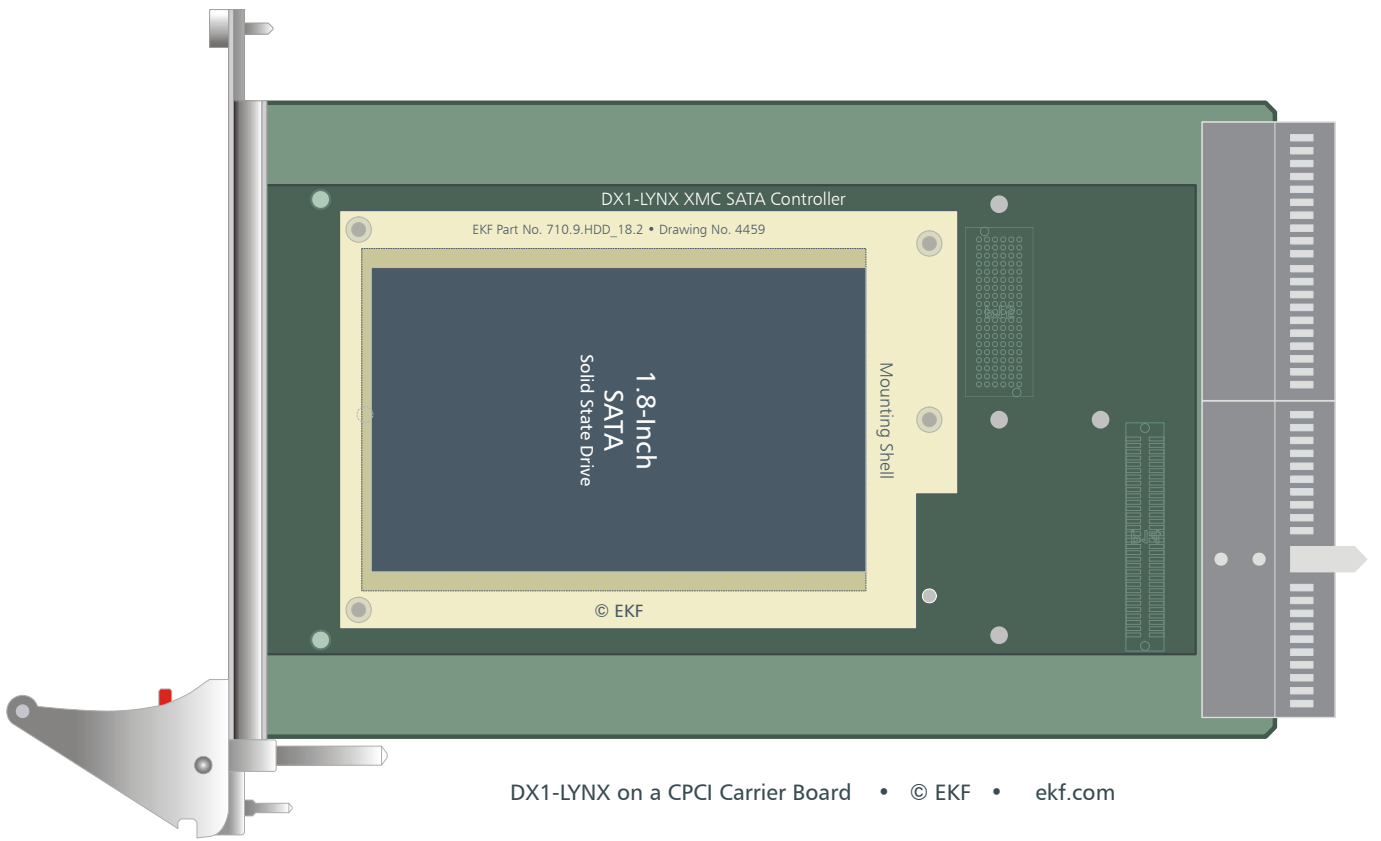

Installing and Replacing Components

Before You Begin

Warnings

The procedures in this chapter assume familiarity with the general terminology associated with industrial electronics and with safety practices and regulatory compliance required for using and modifying electronic equipment. Disconnect any telecommunication links, networks or procedures described in this chapter. Failure links before you open the system or perform or equipment damage. Some parts of the the power switch is in its off state.



the system from its power source and from modems before performing any of the to disconnect power, or telecommunication any procedures can result in personal injury system can continue to operate even though

Caution

Electrostatic discharge (ESD) can damage components. Perform the procedures described in this chapter only at an ESD workstation. If such a some ESD protection by wearing an metal part of the system chassis or board original ESD protected packaging. Retain the antistatic box) in case of returning the board



to EKF for repair. station is not available, you can provide antistatic wrist strap and attaching it to a front panel. Store the board only in its original packaging (antistatic bag and

Installing the Board Assembly

Warning

This procedure should be done only by qualified technical personnel. Disconnect the system from its power source before doing the procedures described here. Failure to disconnect power, or telecommunication links before you open the system or perform any procedures can result in personal injury or equipment damage.

Typically you will perform the following steps:

- Switch off the system, remove the AC power cord
- Attach your antistatic wrist strap to a metallic part of the system
- Remove the board packaging, be sure to touch the board only at the front panel
- Identify the related CompactPCI slot (peripheral slot for I/O boards, system slot for CPU boards, with the system slot typically most right or most left to the backplane)
- Insert card carefully (be sure not to damage components mounted on the bottom side of the board by scratching neighbored front panels)
- A card with onboard connectors requires attachment of associated cabling now
- Lock the ejector lever, fix screws at the front panel (top/bottom)
- Retain original packaging in case of return



Removing the Board Assembly

Warning

This procedure should be done only by qualified technical personnel. Disconnect the system from its power source before doing the procedures described here. Failure to disconnect power, or telecommunication links before you open the system or perform any procedures can result in personal injury or equipment damage.

Typically you will perform the following steps:

- Switch off the system, remove the AC power cord
- Attach your antistatic wrist strap to a metallic part of the system
- Identify the board, be sure to touch the board only at the front panel
- unfasten both front panel screws (top/bottom), unlock the ejector lever
- Remove any onboard cabling assembly
- Activate the ejector lever
- Remove the card carefully (be sure not to damage components mounted on the bottom side of the board by scratching neighbored front panels)
- Store board in the original packaging, do not touch any components, hold the board at the front panel only



Warning

Do not expose the card to fire. Battery cells and other components could explode and cause personal injury.





EMC Recommendations

In order to comply with the CE regulations for EMC, it is mandatory to observe the following rules:

- The chassis or rack including other boards in use must comply entirely with CE
- Close all board slots not in use with a blind front panel
- Front panels must be fastened by built-in screws
- Cover any unused front panel mounted connector with a shielding cap
- External communications cable assemblies must be shielded (shield connected only at one end of the cable)
- Use ferrite beads for cabling wherever appropriate
- Some connectors may require additional isolating parts

Reccomended Accessories

Blind CPCI Front Panels	EKF Elektronik	Widths currently available (1HP=5.08mm): with handle 4HP/8HP without handle 2HP/4HP/8HP/10HP/12HP
Ferrit Bead Filters	ARP Datacom, 63115 Dietzenbach	Ordering No. 102 820 (cable diameter 6.5mm) 102 821 (cable diameter 10.0mm) 102 822 (cable diameter 13.0mm)
Metal Shielding Caps	Conec-Polytronic, 59557 Lippstadt	Ordering No. CDFA 09 165 X 13129 X (DB9) CDSFA 15 165 X 12979 X (DB15) CDSFA 25 165 X 12989 X (DB25)

Technical Reference - Connectors and Jumpers

Caution

Some of the connectors may provide operating voltage (e.g. +12V, +5V and +3.3V) to devices inside the system chassis, such as internal peripherals. Not all of these connectors are overcurrent protected. Do not use these connectors for powering devices external to the computer chassis. A fault in the load presented by the external devices could cause damage to the board, the interconnecting cable and the external devices themselves.

Please Note

The DX1-LYNX mezzanine module may be equipped with several on-board or front bezel connectors for system internal or external usage. Not all of these connectors may be present on a particular board (manufacturing options). Be sure to specify your individual needs when ordering the DX1-LYNX board. Characteristic features and the pin assignments of each connector are described on the following pages.

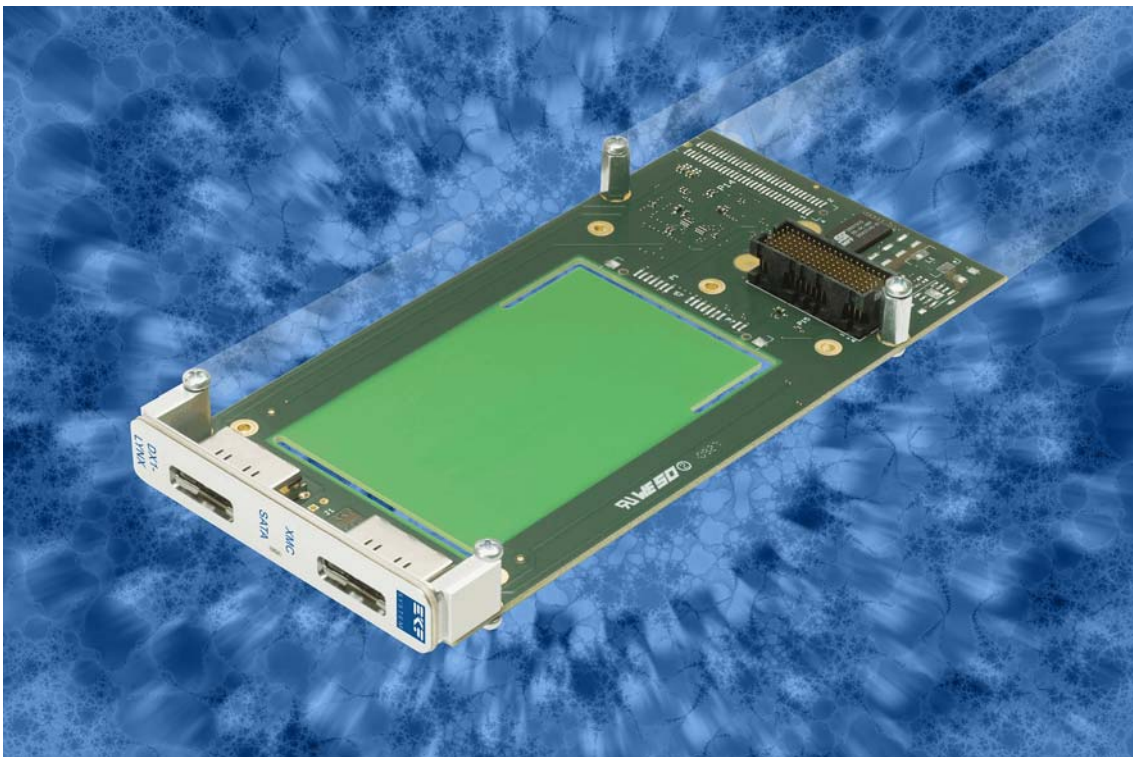

J1 BIOS Selection

EKF CPU cards are capable to boot from a JMB36x based controller, such as the DX1-LYNX, due to built-in code in the CPU card BIOS.

As an option, the DX1-LYNX can be equipped with a 128kx8 Flash memory, which contains the JMB36x BIOS, as required for system boot in a non-EKF environment.

Boot code is provided for both operation modes, either normal (non-RAID) or RAID. Selection between these modes is done by the jumper J1:

Jumper J1 • BIOS Selection	
J1 SET	RAID BIOS
J1 REMOVED	Normal BIOS

The Flash BIOS will be required for the boot-phase only, at system startup time, with the operation system being installed on a drive attached to the DX1-LYNX. If the DX1-LYNX is intended for use as a non-boot mass storage controller, the Flash memory can be omitted.

Since the Flash is directly soldered to the PCB, this is a stuffing option - please consider before ordering.

In addition, JMB36x drivers must be installed, suitable for the particular operation system in use. Latest drivers and BIOS versions are available for download at: <ftp://driver.jmicron.com.tw/jmb36x/>

P1 P2 Micro SATA Receptacles

The DX1-LYNX can accommodate one or even two 1.8-inch SATA standard form factor drive(s) according to the SFF-8144 specification, which results in a 5.0 mm maximum height, and 78.5mm x 54.0mm dimensions. The Micro SATA connector in use is defined in Serial ATA Rev. 2.6. Devices with 8.0mm height (probably only hard disk) should be avoided.

A mounting frame is used to hold each drive, for extremely rugged applications.

DX1-LYNX on a CPCI Carrier Board - Sectional Drawing • © EKF • ekf.com

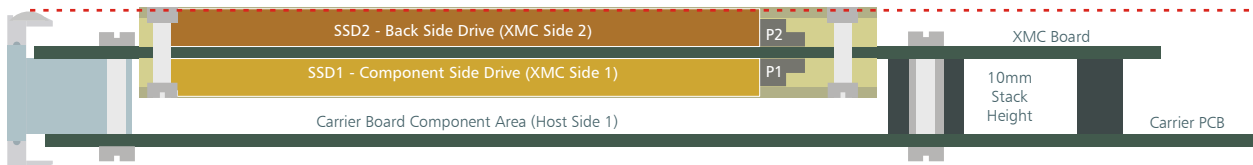

The DX1-LYNX can be provided with up to two Micro SATA docking connectors. While the component side connector P1 and the associated 5mm height drive fully comply with the VITA 42 (XMC) specification, P2 and a back side drive would slightly exceed the maximum component height defined by IEEE 1386 (CMC). This may be tolerable however for typical carrier boards with 4HP front panel width and a 10mm XMC to host stack height - please verify before ordering.

Usage (population) of P1/P2 is exclusive to other optional connectors (front bezel, or rear I/O). P1 is exclusive to P3 (front bezel eSATA #1), and P2 is exclusive to P4 (front bezel eSATA #2). In addition, P1 and P2 are exclusive to P14 (rear I/O) with respect to the particular SATA channel(s). These are assembly options (manufacturing phase) and cannot be configured by the customer itself - please consider before ordering a DX1-LYNX version which is suitable to your individual needs.

If two drives are attached to the DX1-LYNX (any combination of internal - external - rear I/O), the JMB363 SATA controller can be operated in a low level RAID mode (0/1/10), as an option. Suitable drivers, either RAID or non RAID, are available for download from: <ftp://driver.jmicron.com.tw/jmb36x/>



P1 / P2 • Micro SATA Docking Connectors 7+9 • 256.016.10.01



S1	GND
S2	TX+ SATA0/1
S3	TX- SATA0/1
S4	GND
S5	RX- SATA0/1
S6	RX+ SATA0/1
S7	GND
P1	+3.3V
P2	+3.3V
P3	GND
P4	GND
P5	+5V
P6	+5V
P7	DAS (R to GND)
P8	NC
P9	NC

Signal designations RX/TX are assigned with respect to the SATA host controller (JMB363). The SATA channel 0 is dedicated to P1, and SATA channel 1 corresponds to P2.

Typical Micro SATA SSD devices are powered from a single +3.3V rail. Power is supplied from the host carrier board, across the DX1-LYNX mezzanine connector P15 (3.3V pins). As an option, the DX1-LYNX can be equipped with a voltage regulator, which converts the XMC VPWR (either 12V or 5V) to the +3.3V on-board power plane.

The optional voltage regulator can also be configured (assembly option) for sourcing +5V to P1/P2, derived from XMC VPWR (+12V VPWR assumed). Normally this voltage converter will not be needed and is consequently not stuffed by default.

Note: Do not confuse the Micro SATA connector specified by Serial ATA Rev. 2.6 with the proprietary 'Special SATA' connector as defined by Samsung (refer to *Samsung 1.8" Form Factor Proposal*).

P3 P4 eSATA Connectors

The DX1-LYNX front bezel may provide up to two eSATA receptacles for attachment of external SATA devices, P3 and P4. P3 corresponds to the JMB363 SATA controller channel 0, and P4 is wired to SATA channel 1.

TX/RX designation of signals are shown with respect to the SATA controller JMB363. Shielded external SATA cable assemblies are recommended for reliable industrial usage.

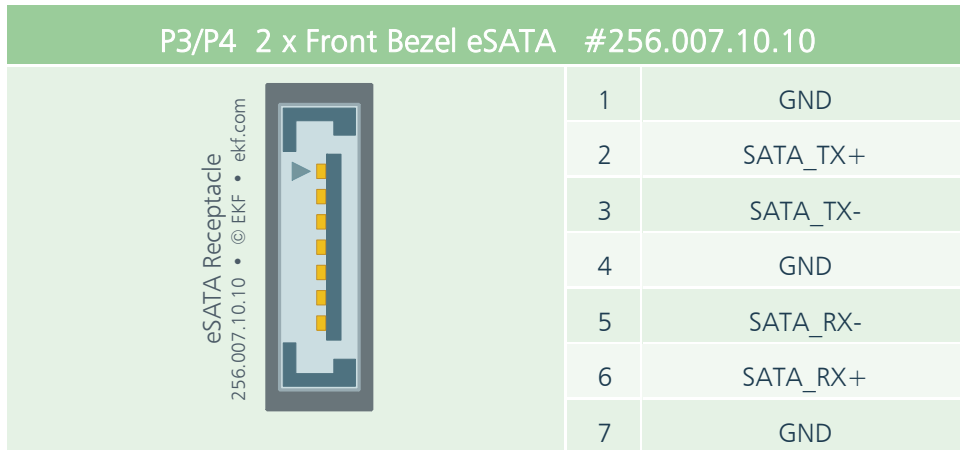

The typical external cable length should not exceed 2m. Remember that SATA is a high speed data link. Choose the minimum distance possible for locating the external SATA device, and use high quality cable assemblies for reliable industrial operation, such as the Molex 68782 series (EKF part no. 256.007.82.10 and 256.007.82.20). Compared to internal SATA cabling, the eSATA front bezel connectors offer superior shielding and provide EMI protection. eSATA connectors and cable harnesses used or supplied by EKF adhere to the design specifications recommended by the Serial ATA International Organization (SATA-IO).

For experimental purposes, there are also adapter cable assemblies available from eSATA to SATA (EKF part no. 256.007.81.10).

Assembly of P3 (eSATA #1) is exclusive to P1 (side 1 on-board drive) and P14 (SATA channel 0 rear I/O usage). Stuffing of P4 (eSATA #2) is exclusive to P2 (side 2 on-board drive) and P14 (SATA channel 1 rear I/O usage). These are assembly options (manufacturing phase) and cannot be configured by the customer itself - please consider before ordering a DX1-LYNX version which is suitable to your individual needs.

If two drives are attached to the DX1-LYNX (any combination of internal - external - rear I/O), the JMB363 SATA controller can be operated in a low level RAID mode (0/1/10), as an option. Suitable drivers, either RAID or non RAID, are available for download from: <ftp://driver.jmicron.com.tw/jmb36x/>

P14 Mezzanine Connector

As an option, one or both SATA channels can be made available for rear I/O usage via P14, a PMC style plug. P14 mates with J14 on a host carrier board. A suitable rear I/O transition module must be attached in addition to the XMC/PMC carrier card.

Assembly of P14 is exclusive to P1 (side 1 on-board drive) and P3 (SATA channel 0 front bezel I/O), and also exclusive to P2 (side 2 on-board drive) and P4 (SATA channel 1 front bezel I/O). These are assembly options (manufacturing phase) and cannot be configured by the customer itself - please consider before ordering a DX1-LYNX version which is suitable to your individual needs.

If two drives are attached to the DX1-LYNX (any combination of internal - external - rear I/O), the JMB363 SATA controller can be operated in a low level RAID mode (0/1/10), as an option. Suitable drivers, either RAID or non RAID, are available for download from: <http://driver.jmicron.com.tw/jmb36x/>

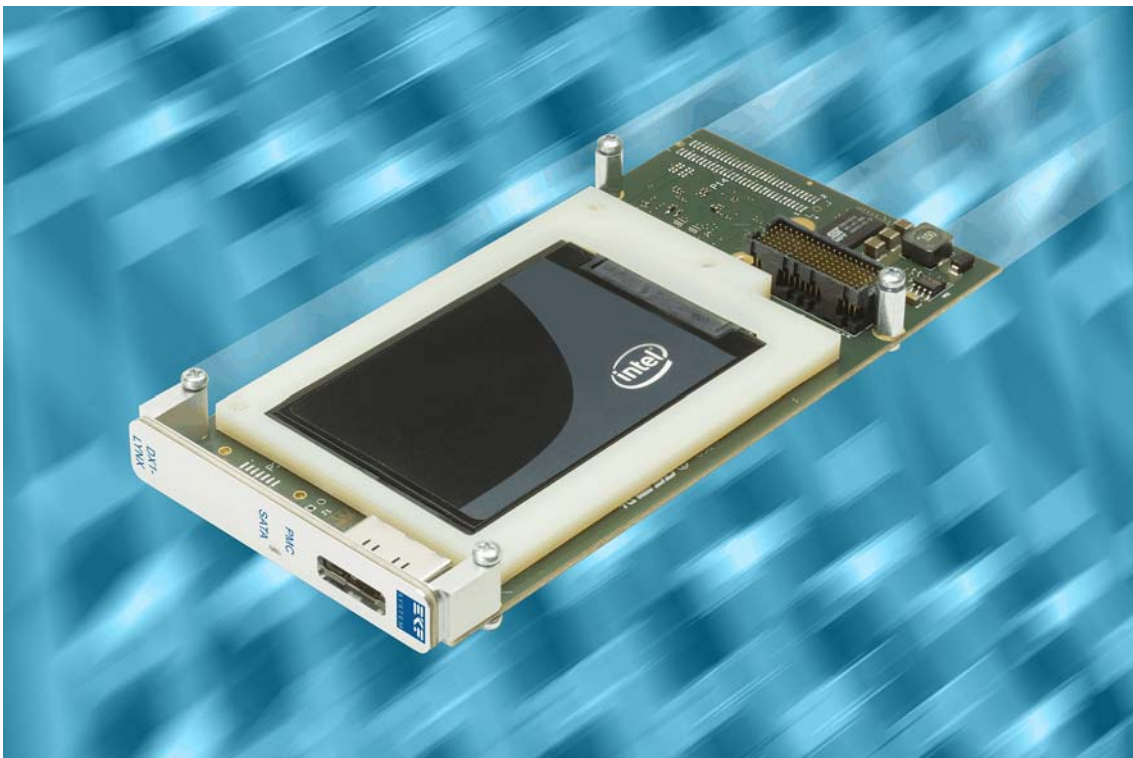

P14 • Rear I/O Option • 275.02.08.064.03

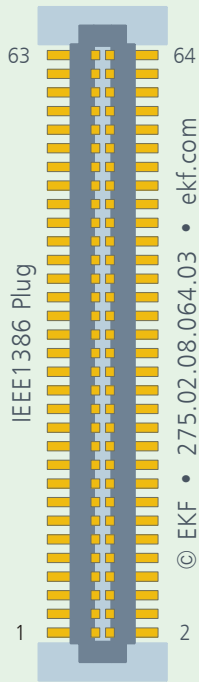

© EKF • 275.02.08.064.03 • ekf.com

	63	64	
	61	62	
GND	59	60	GND
SATA0_RX+	57	58	GND
SATA0_RX-	55	56	GND
GND	53	54	GND
SATA0_TX-	51	52	GND
SATA0_TX+	49	50	GND
GND	47	48	GND
JMB_LED#	45	46	GND
+3.3V	43	44	GND
	41	42	
GND	39	40	GND
SATA1_RX+	37	38	GND
SATA1_RX-	35	36	GND
GND	33	34	GND
SATA1_TX-	31	32	GND
SATA1_TX+	29	30	GND
GND	27	28	GND
	25	26	GND
+3.3V	23	24	GND
	21	22	
	19	20	
	17	18	
	15	16	
	13	14	
	11	12	
	09	10	
	07	08	
	05	06	
	03	04	
	01	02	

P15 Mezzanine Connector

The DX1-LYNX is equipped with a high speed XMC mezzanine connector P15, mating with the host board J15 and establishing the data path (PCI Express) and power link to the carrier. The pin assignment of P15/J15 is specified by VITA 42.3. The DX1-LYNX is organized as single-lane single-link PCI Express device.

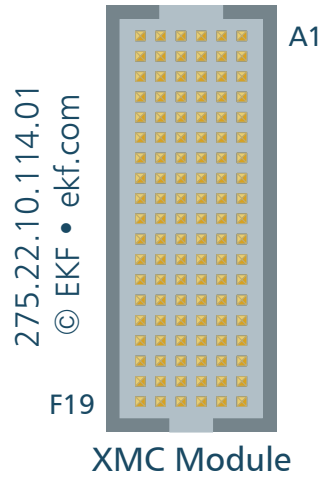

ANSI/VITA 42.3 defines a primary XMC connector P15, which is mandatory (for PCIe fabric), and a secondary XMC connector P16, which is optional (either fabric or user I/O). The DX1-LYNX does not make use of P16. With respect to rear I/O, please refer to the description of P14 (PMC style connector).



Suitable carrier cards are available from EKF, e.g. the SK2-SESSION CompactPCI® Serial XMC module carrier board.

XMC Connector P15 - PCIe Fabric • EKF Part No. 275.22.10.114.01						
	A	B	C	D	E	F
1	PETOP0	PETON0	+3.3V	<i>PETOP1</i>	<i>PETON1</i>	VPWR ²⁾
2	GND	GND	TRST# ¹⁾	GND	GND	MRSTI#
3	<i>PETOP2</i>	<i>PETON2</i>	+3.3V	<i>PETOP3</i>	<i>PETON3</i>	VPWR ²⁾
4	GND	GND	TCK	GND	GND	MRSTO#
5	<i>PETOP4</i>	<i>PETON4</i>	+3.3V	<i>PETOP5</i>	<i>PETON5</i>	VPWR ²⁾
6	GND	GND	TMS	GND	GND	+12V
7	<i>PETOP6</i>	<i>PETON6</i>	+3.3V	<i>PETOP7</i>	<i>PETON7</i>	VPWR ²⁾
8	GND	GND	TDI	GND	GND	-12V
9	<i>RFU</i>	<i>RFU</i>	<i>RFU</i>	<i>RFU</i>	<i>RFU</i>	VPWR ²⁾
10	GND	GND	TDO	GND	GND	GA0 ¹⁾
11	PEROP0	PERON0	MBIST#	<i>PEROP1</i>	<i>PERON1</i>	VPWR ²⁾
12	GND	GND	GA1 ¹⁾	GND	GND	MPRESENT#
13	<i>PEROP2</i>	<i>PERON2</i>	+3.3V_AUX	<i>PEROP3</i>	<i>PERON3</i>	VPWR ²⁾
14	GND	GND	GA2 ¹⁾	GND	GND	MSDA ¹⁾
15	<i>PEROP4</i>	<i>PERON4</i>	<i>RFU</i>	<i>PEROP5</i>	<i>PERON5</i>	VPWR ²⁾
16	GND	GND	MVMRO	GND	GND	MSCL ¹⁾
17	<i>PEROP6</i>	<i>PERON6</i>	<i>RFU</i>	<i>PEROP7</i>	<i>PERON7</i>	<i>RFU</i>
18	GND	GND	<i>RFU</i>	GND	GND	<i>RFU</i>
19	CLKP_XMC	CLKN_XMC	<i>RFU</i>	WAKE#	ROOT0#	<i>RFU</i>

pin positions printed italic/gray: reserved by specification / not connected

- 1) Serial EEPROM not populated by default (no IPMI)
- 2) VPWR typically is not required - both the SATA controller and the SSD are sourced from +3.3V



SK2-SESSION • CompactPCI® Serial • XMC Module Carrier Board

www.ekf.com/s/sk2/sk2.html

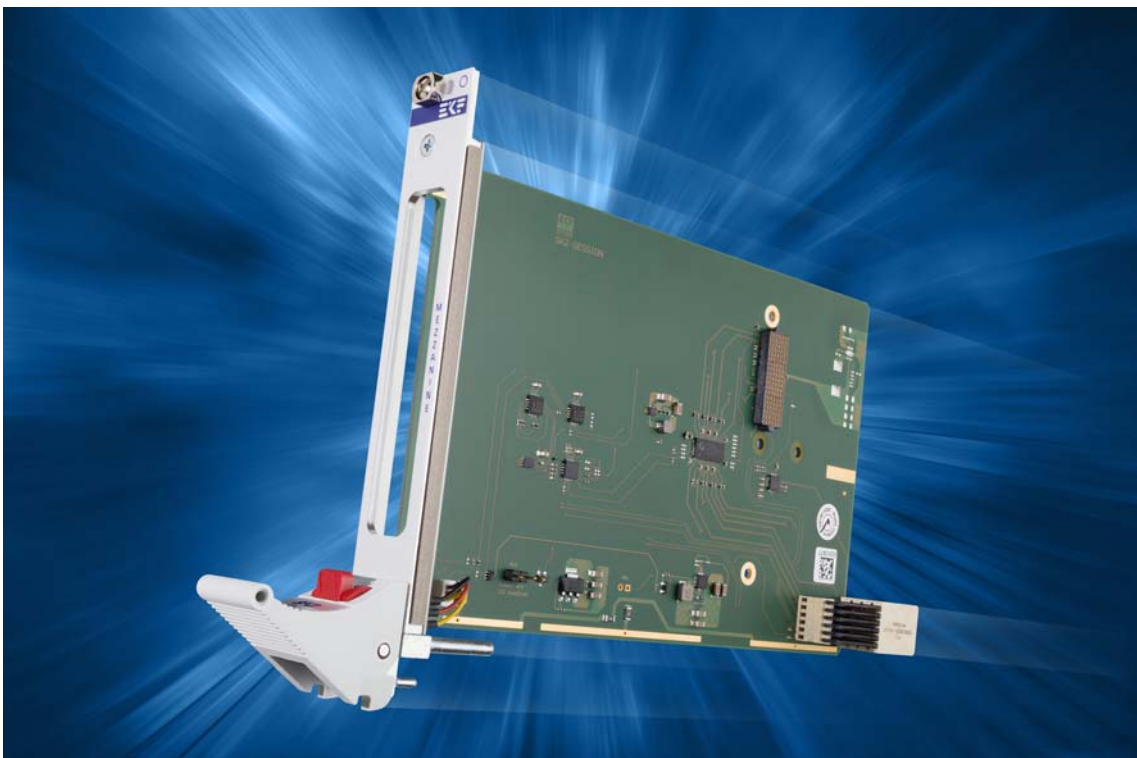

SK2-SESSION • CompactPCI® Serial • XMC Module Carrier Board

Schematics

Complete circuit diagrams for this product are available for customers on request. Signing of a non-disclosure agreement would be needed. Please contact sales@ekf.de for details.

EKF reserves the right to refuse distribution of confidential information material for any reason that EKF may consider substantial.



Industrial Computers Made in Germany
boards. systems. solutions.

EKF Elektronik GmbH
Philipp-Reis-Str. 4
59065 Hamm
Germany



Phone +49 (0)2381/6890-0
Fax +49 (0)2381/6890-90
Internet www.ekf.com
E-Mail sales@ekf.com